

Friktionsfäste / Friction attachment / Friktionsbefestigung  
med bygel with clamp mit Bügel

# 144 / E-Serie

Art.nr 800780

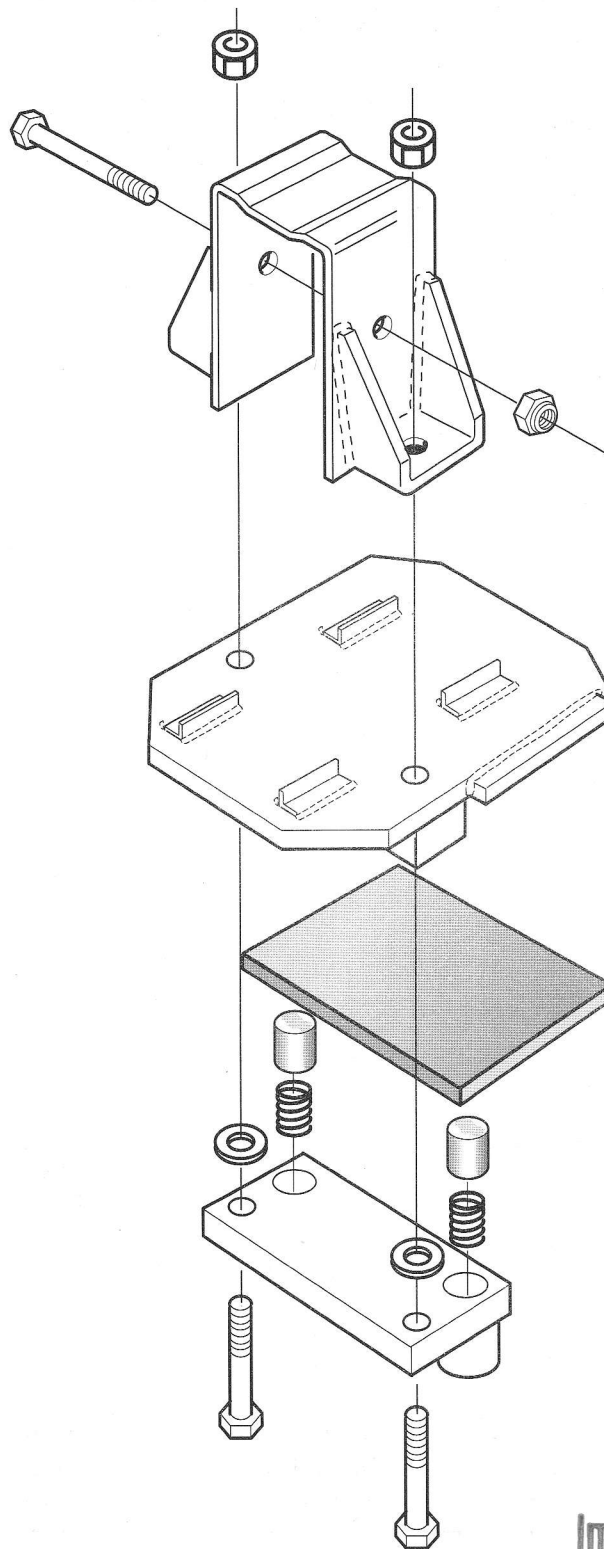

# ExTe

Securing cargo. We invented the concept.

Implementos  Logísticos

Camino de Ronda, 77 - 8º J - 18004 GRANADA  
Tlf. 958 52 28 38 - Fax 958 26 55 60  
Móvil 609 828 781

# Mått / Dimension / Einbaumasse

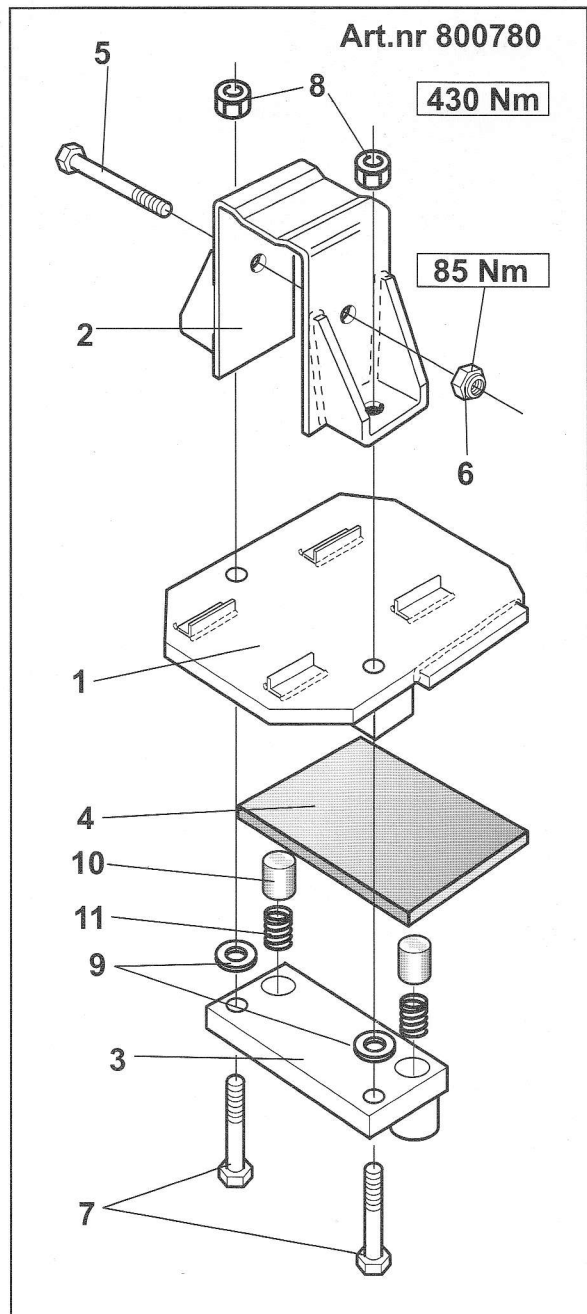
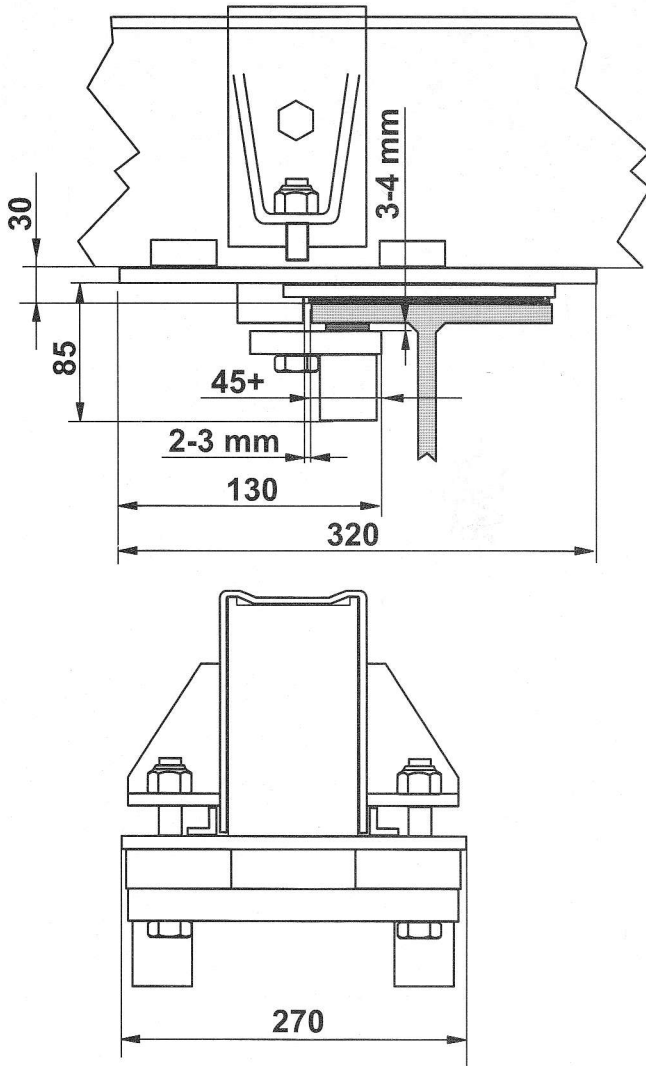

**Vikt / Weight / Gewicht: 16.8 kg**

pos	Nr/No	Beskrivning	Description	Bezeichnung	anm.note
1.	800 771	Monteringsplatta	Mounting plate	Grundplatte	8.7 kg
2.	800 765	Överbygel	Upper part	Bügel oben	3.8 kg
3.	800 602	Underplatta	Fastening plate	Führungsplatte unten	3.5 kg
4.	800 647	Glidplatta 15 mm	Sliding pad 15 mm	Gleitplatte 15 mm	
--	800 646	Glidplatta 20 mm	Sliding pad 20 mm	Gleitplatte 20 mm	
5.	211 098	Skruv	Screw	Schraube	M12x140
6.	211 857	Mutter	Nut	Mutter	M12 lock
7.	211 171	Skruv	Screw	Schraube	M20x140
8.	211 861	Mutter	Nut	Mutter	M20 lock
9.	800 644	Bricka	Washer	Scheibe	
10.	800 603	Plastplunch	Plastplunge	Ausgleichspilz	
11.	800 604	Fjäder	Spring	Spiralfeder	

# ExTe